

REVISIONS				
ZONE	REV	DESCRIPTION	DATE	APPROVED

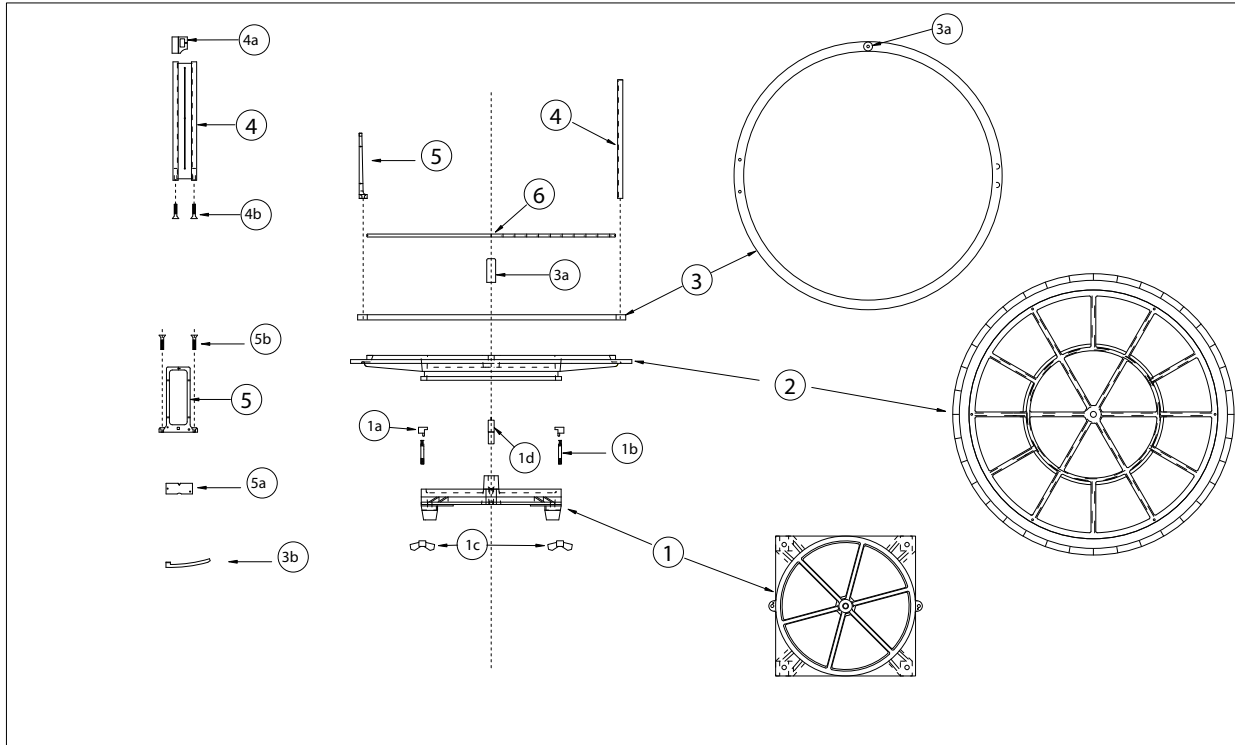

1	Base				
2	Azimuth Ring				
3	Sight Ring				
4	Rear Sight				
5	Front Sight				
6	Distance Tape				
1a	Clamping Head				
1b	Clamping Stud; 1/4 -20 x 2"				
1c	Wing Nut				
1d	Center Pin				
3a	Ring Handle				
3b	... Tab				
4a	Sight Slider				
4b	#10 -24 machine screws				
5a	Night Sight				
5b	#12 -24 machine screws				

DRAFT

		SIZE	FSCM NO.	DWG NO.	REV
		SCALE			SHEET